



# Technitron T6700 Series

## Fixed Frequency DC Inverter



### Medium Frequency DC Inverter Resistance Weld/Machine Control

The T6700 Series controls give a machine builder everything they need to control the resistance welding and the entire machine functionality, all built into one powerful, cost effective package. The T6700 Series utilizes the Allen Bradley™ SLC500 system to provide flexibility and configuration options to meet anyone's needs.

#### Key Features

#### Unlimited Machine Control Capabilities

With the Allen Bradley™ SLC system, machine control possibilities are unlimited. With choices of different processors, robot controls, networking cards, and Build Your Own I/O, there is nothing you cannot do with this resistance weld/machine control.

#### Reduce Scrap

With the constant current feedback rate between 400 to 2000 times per second, the T6700 series maintains a consistent current weld after weld, and if something were to go wrong, the built in monitor alerts the operator.



#### Increase Tooling Life

Due to the medium frequency DC output of the T6700 Series, the secondary of the welding loop stays energized constantly compared to cycling of the conventional AC welder, typically allowing the welds to be done at lower currents, shorter weld times, and lower pressures. Because of this, electrodes and tooling have a longer life, cutting on machine down time to dress and change tooling.

#### Lower Power Consumption

Due to the three-phase draw of the T6700 Series control, there is a lower peak draw during the weld that can reduce the power bill up to 30% over conventional AC weld controls



# Technitron T6700 Series

## Fixed Frequency DC Inverter



### Standard Features

- 480VAC 3-phase 50/60Hz
- 600 Amp IGBTs (T6706) / 1200 Amp IGBTs (T6712)
- Expandable 7 slot rack mount system
- AVC (% of Heat) and constant current with option of implementing both within same sequence
- Primary or Secondary current monitoring and control
- Welding data monitored at 400 to 2000 times per second
- 16/16 I/O; 24VDC input and relay output; capable of 160I/O
- Allen Bradley™ Remote I/O capability
- Robot I/O interface capabilities
- Built in PLC for special welding applications and or complete control of small welding machines
- 99 available programmable sequences, each with programming space for 99 weld schedules
- Schedules stored in EEPROM memory, keeping them safe from dying batteries
- 4 default programs accessible through a Default Library (stored in fixed EEPROM area)
- 99 available welding sequence instructions predefined
- 40 faults
- 99 available linear or Sure Weld steppers

### Options

- 500VA valve power supply
- Power lugs or circuit breaker  
200 Amp (T6706)  
400 or 600 Amp (T6712)
- Isolation Contactor  
Size 4 (T6706)  
Size 5 (T6712)
- 5/03 processor
- Analog pressure control
- Integral gun kit
- DeviceNet
- Remote Data Entry Panel

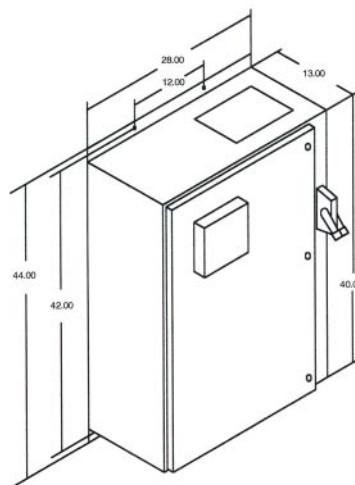

Effective Date: July 2002  
Data Sheet #: ML-00232 R1.1