

Technitron T3005

Single or Multi SCR AC Control



Free Format Constant Current PLC Based Control

The T3005 gives a machine builder everything they need to control the resistance welding and the entire machine functionality, all built into one powerful, cost effective package. The T3005 utilizes the Allen Bradley™ SLC500 system to provide flexibility and configuration options to meet anyone's needs.

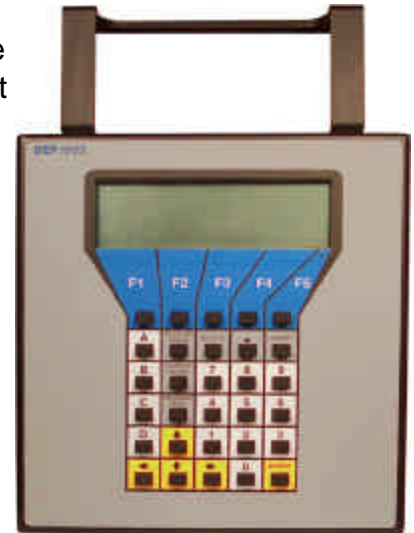

Key Features

- 99 fully programmable free form weld schedules and heat steppers
- Monitoring and limits for voltage, current, power factor, and C-factor
- Automatic voltage compensation and current regulation
- Wait for line voltage function eliminates need for hard system interlock
- Automatic re-weld on low current fault
- Test fire function for tips touching and slow cylinder detection
- Up slope, pre-weld, impulse, seam, roll-spot, post-weld, and down-slope functions standard
- Dynamic power factor compensation
- Removable Data Entry Panel (DEP)
- Network ready
- Discrete, RIO, and DIO initiation available



Technitron T3005

Single or Multi SCR AC Control



Standard Features

- 240/480/600 VAC 50/60Hz
- 1200 Amp 50% D.C. SCR module (1-8)
- Expandable seven slot rack mount system
- AVC (% Heat) and constant current with capability of implementing both within the same schedule
- Primary or secondary current monitoring and control
- Welding data monitored on ½ cycle basis
- Single SCR 16/16 I/O; Multi SCR 16/24 I/O
- 16/16 I/O; 24VDC input and relay output; capable of 160 I/O
- Allen Bradley™ Remote I/O capability
- Robot I/O interface capabilities
- Built-in-PLC for special welding applications and/or complete control of small welding machines
- 99 available programmable schedules, each with programming space for up to 99 weld functions
- Schedules stored in EEPROM memory, keeping them safe from dying batteries
- 4 default programs accessible through a Default Library (stored in fixed EEPROM area)
- 99 available welding sequence instructions predefined
- 40 faults
- 99 available linear or SureWeld steppers

Options

- 250 or 400 Amp 2 or 3 pole circuit breaker
- Size 4 or 5 isolation contactor
- 100% duty cycle SCRs
- 5/03 or 5/04 processor module
- WebVIEW software and master workstation
- Additional I/O available
- Remote Data Entry Panel
- Integral gun kit for manual or automatic operation
- DeviceNet
- 10" secondary current coil
- Analog pressure control



T3005 Kit

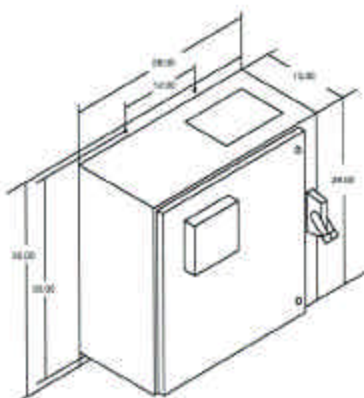

"ST" Enclosure

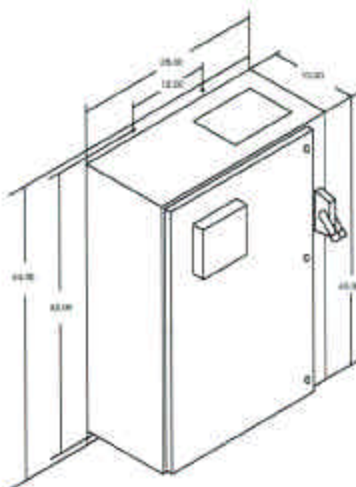

"ML" Enclosure

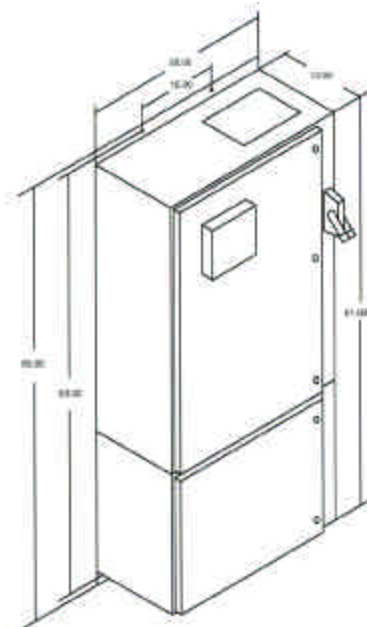

"ML-Aux" Enclosure

Effective Date: July 2002
Data Sheet #: ML-00210 R1.2